

(No Model.)

3 Sheets—Sheet 1.

J. LINDSTROM & E. F. BERGMAN.
LATHE ATTACHMENT FOR TURNING MACHINES.

No. 464,757.

Patented Dec. 8, 1891.

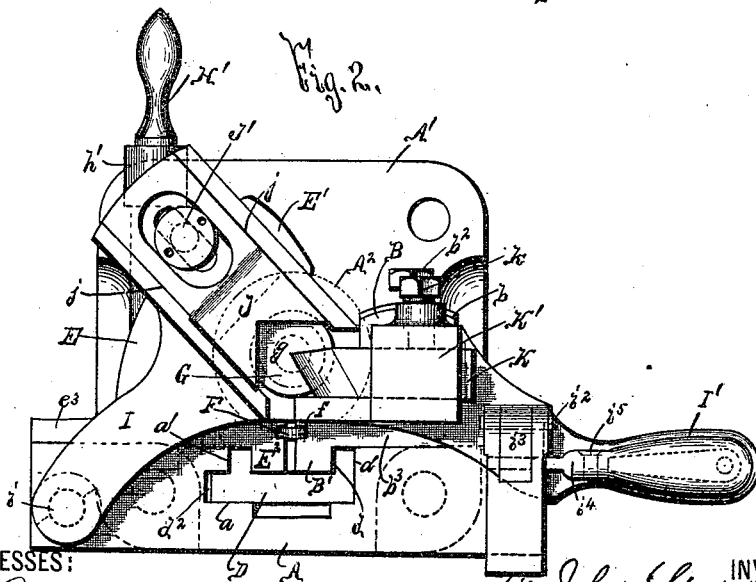
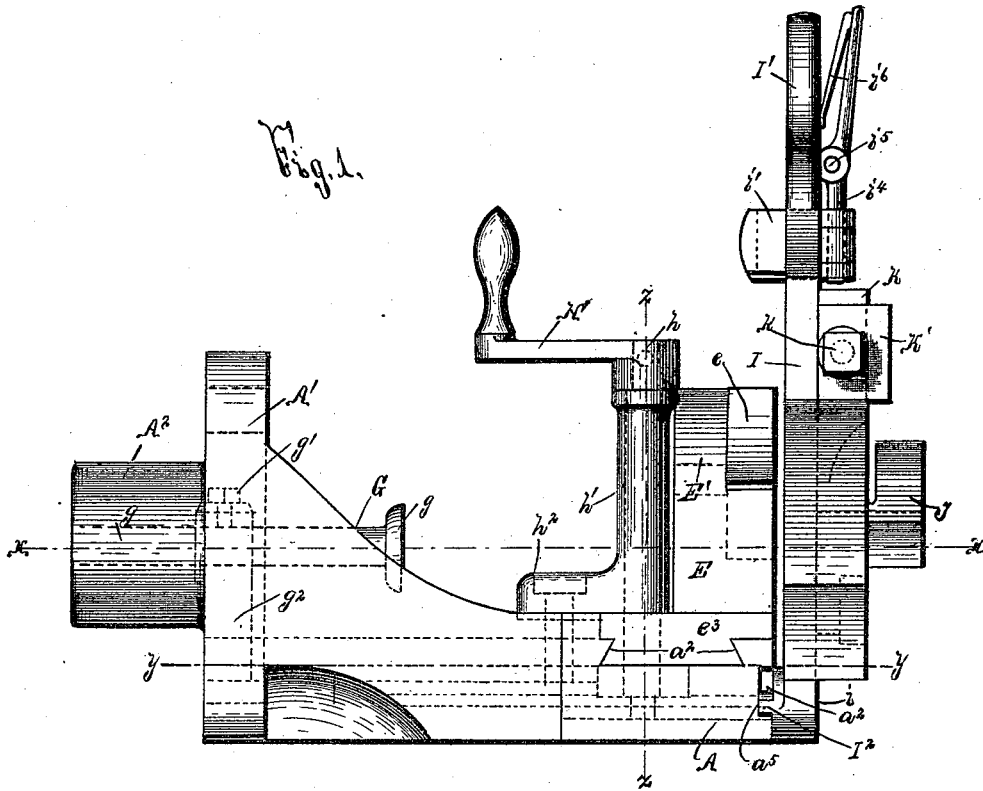

WITNESSES:

W. H. Randall,
H. C. Chase,

INVENTORS

John Lindstrom
Edward F. Bergman
Attorneys
ATTORNEYS.

(No Model.)

3 Sheets—Sheet 2.

J. LINDSTROM & E. F. BERGMAN.
LATHE ATTACHMENT FOR TURNING MACHINES.

No. 464,757.

Patented Dec. 8, 1891.

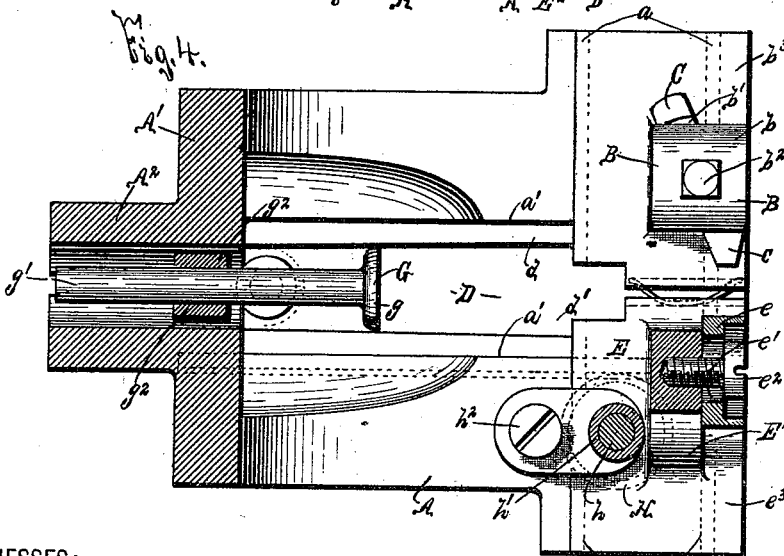
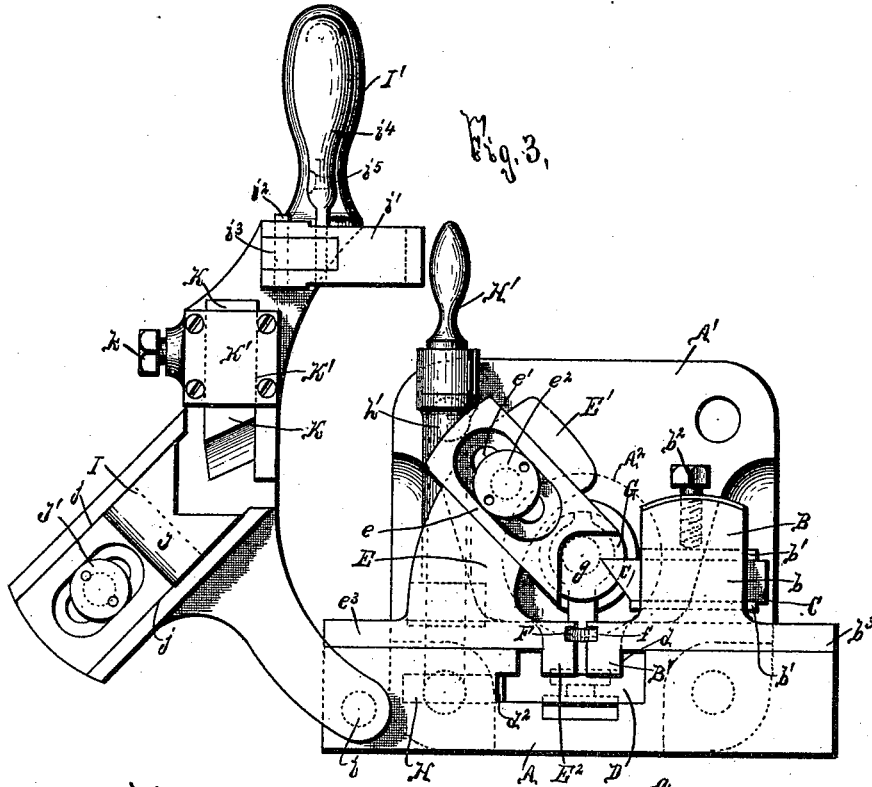

WITNESSES:

W. H. Randall,
H. E. Chase

INVENTORS

John Lindstrom
Edward F. Bergman

BY

Hay Wilkinson
ATTORNEYS

(No Model.)

3 Sheets—Sheet 3.

J. LINDSTROM & E. F. BERGMAN.
LATHE ATTACHMENT FOR TURNING MACHINES.

No. 464,757.

Patented Dec. 8, 1891.

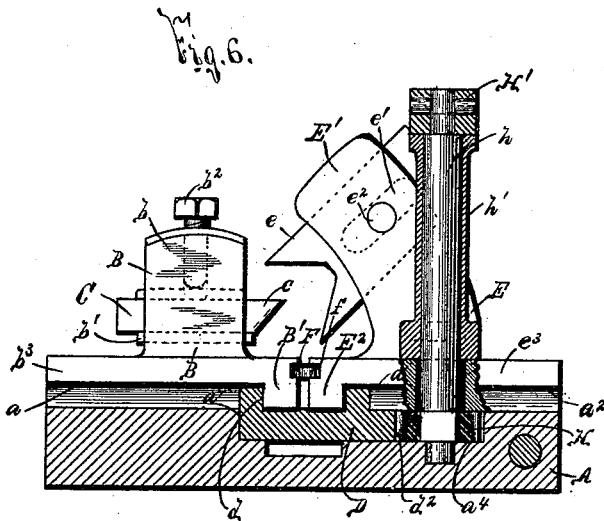
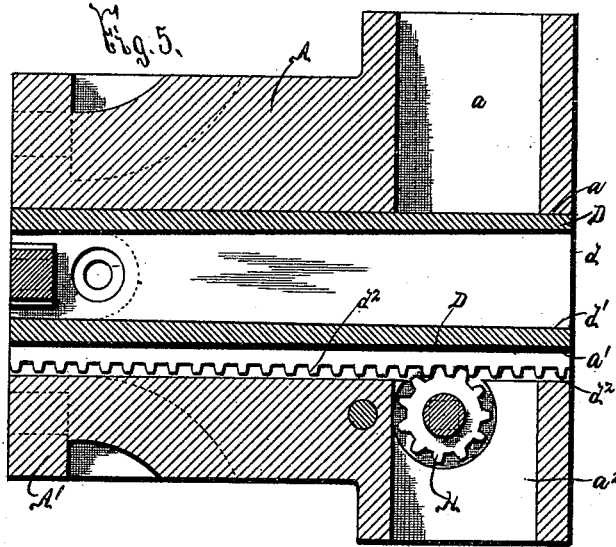

WITNESSES:

W. B. Randall,
H. C. Chase

INVENTORS

John Lindstrom
Edward F. Bergman

BY

Henry Wilkinson Parsons
ATTORNEYS

UNITED STATES PATENT OFFICE.

JOHN LINDSTROM AND EDWARD F. BERGMAN, OF FRANKFORT, NEW YORK.

LATHE ATTACHMENT FOR TURNING-MACHINES.

SPECIFICATION forming part of Letters Patent No. 464,757, dated December 8, 1891.

Application filed February 7, 1891. Serial No. 380,701. (No model.)

To all whom it may concern:

Be it known that we, JOHN LINDSTROM and EDWARD F. BERGMAN, of Frankfort, in the county of Herkimer, in the State of New York, have invented new and useful Improvements in Straight or Taper Bolt or Stud Attachments, of which the following, taken in connection with the accompanying drawings, is a full, clear, and exact description.

Our invention relates to an improved attachment for lathes and like turning-machines for forming straight or tapered bolts or rods, and has for its object the production of a simple and effective device capable of ready attachment at will to such machines, which when once adjusted brings the bolts or rods to the desired conformation with great rapidity and uniformity without the necessity of careful attention; and to this end it consists, essentially, in a cutting-tool support movable on the frame toward the article to be cut, a movable adjuster for varying the position of the cutting-tool support, and a contact-plate secured to the adjuster in the path of the article to be cut for bringing the adjuster into operation.

The invention furthermore consists in a support adjustably mounted on the frame oppositely arranged with and movable toward the tool-support, a spring between the two supports, and a chamfering-tool movable toward and away from the article to be cut; and it still furthermore consists in the detail construction and arrangement of the parts, all as hereinafter more particularly described, and pointed out in the claims.

In describing this invention reference is had to the accompanying drawings, forming a part of this specification, in which like letters indicate corresponding parts in all the views.

Figures 1 and 2 are respectively side and front elevation of the parts of our invention, the chamfering-tool being shown as out of operative position in Fig. 1 and as in operation in Fig. 2. Fig. 3 is a front elevation of the parts as illustrated in Fig. 1. Fig. 4 is a horizontal sectional view taken on line $x x$, Fig. 1. Fig. 5 is a horizontal sectional view taken on line $y y$, Fig. 1; and Fig. 6 is a vertical sectional view taken on line $z z$, Fig. 1.

It is well known that in forming bolts and other similar rods it is very desirable to form

a portion thereof cylindrical and the remaining portion of an accurate and uniform taper. Our invention is designed to effect this desirable result automatically, accurately, and rapidly without the necessity of the operator frequently changing the cutting-tool.

A represents the frame of our invention, which may be of any desirable form, size, and construction suitable for attachment to any style of lathe or screw-cutting machine. The frame illustrated is provided with a rear plate A' and a hollow rearwardly-extending hub A² for attachment to the tail-stock of a lathe.

B represents the tool-support consisting of the upwardly-extending head b , in which the cutting-tool C is adjustably held by the plates b' b'' and the clamping-screw b^2 . The base b^3 of the support is movable in guides a in the top face of the frame and is provided with the depending rib B', which rides in the guide-way d of the movable plate or adjuster D. This adjuster is movable in a guide a' in the frame, and the guide d of the adjuster tapers gradually from one extremity to the other in a plane at substantially right angles to the plane in which the tool-support moves within the guides a . As illustrated, this taper is identical with that adopted as the United States standard for bolts and screws, since our attachment is particularly useful in manufacturing bolts and screws; but it will be evident that the guide d may conform to any desired taper for producing any particular construction of tapered bolt or rod.

Oppositely arranged to the cutting-point of the cutting-tool C is the support E, having an upwardly-extending head E', upon which is adjustably mounted a bearing-face e , having at one end a slot e' , through which passes a clamping-screw e^2 . The base e^3 of the support E is movable in guides a^2 , oppositely arranged to the guides a , and is provided with a depending rib E², which is movable in a guide d' , conforming in taper to that of the guide d . Between the two guides, in a seat or slot f formed in their adjacent sides, is a spring F, which serves to firmly press the ribs E² and B' upon the respective supports E and B against the guides d d' and prevent any lost movement and consequent chattering of the bolt.

G represents a contact-plate movable at

right angles to the supports E and B, with one face g in the path of the article to be cut, and the other provided with a shank adjustably secured by a clamp g' to a standard g^2 , rising from the rear end of the adjuster D. Formed on one edge of the adjuster D are teeth d^2 , which are engaged by a spur-gear H, that is mounted in a recess a^4 in the guide a^3 on a shaft h . The lower extremity of the shaft h is passed through a slot in the base e^3 of the support E, and is journaled beneath said base in the frame A, and its upper extremity is journaled in a bracket h' , secured at h^2 to the frame A, and is provided with a crank H'. It will thus be understood that as the crank H is revolved the gear H', engaged with the adjuster D, forces the same forward or backward as may be desired.

When desired to cut a bolt cylindrically for one inch of its length and tapering the remainder, the crank H is revolved to bring the plate G within one inch of the cutting-tool. As the bolt is fed between the bearing-face e and the tool C it is turned cylindrically until its rear end contacts with the contact-plate G, which it immediately forces backward, and thus automatically forces the adjuster backward. Consequently the remainder of the bolt is turned tapering, since as the adjuster is forced backward by the moving bolt the constant taper of its guides d and d' permits the natural strain upon the supports B and E and the spring F, which forces the ribs B' and E² of said supports B and E against the guides d d' to constantly separate said supports B and E, according as the distance increases between those portions of said guides d d' engaged by the ribs B' and E². After this bolt is finished any desired number may be formed in the same manner with absolute certainty, regularity, and with great speed without the necessity of careful attention on the part of the operator, since the bolt automatically varies the position of the cutting-tool and the oppositely-arranged bearing-face without attention from the operator.

When desired to vary the length of the tapered portion, the screw g' may be loosened and the contact-plate set at a different point, or the handle H may actuate the contact-plate to a position nearer to or farther from the cutting-tool, thus permitting a great variation in the length of taper attainable in the use of our machine. Moreover by supplying our frame with a series of adjusters having their guides d and d' formed of a greater or less taper, it is evident that the amount of taper to the bolt or rod formed may be greatly varied, and instead of tapering the guides from the rear end of the adjuster outwardly they may be tapered exactly opposite.

For the purpose of chamfering the end of the bolt before the operation of the knife C, we provide the bracket I, hinged at one extremity i to the frame A and provided at the other with a hand-engaging lever I', and a

movable catch i' for engaging the frame, as shown in Fig. 2, to retain the bracket in its operative position.

J represents a bearing-face movable in guides j on the bracket I, and adjustably secured thereto by the clamping-screw J', and K represents a cutting-tool oppositely arranged with a bearing-face J, with its rear extremity mounted in a guide K' and held in position by a clamping-screw k . As best seen in Figs. 1, 2, and 3, the catch i' is pivoted at i^2 to a hub i^3 projecting from the free end of the bracket, and is engaged by one end of a lever i^4 , pivoted at i^5 to the handle I', with a spring i^6 interposed between said handle I' and lever i^4 for normally forcing the catch to its position illustrated in Fig. 1. When desired to remove the bracket from operative position, the lever i^4 is rocked, the catch i' swung from operative position, and the bracket rocked against a stop-shoulder I², which may be either formed upon the frame A or the lever I', being here illustrated as formed on the hub of the bracket and movable in a slot a^5 in the frame.

The parts of our invention are very simple in construction and operation, are durable, strong, and effective in use, and when operatively assembled produce a very cheap and desirable attachment that can be readily applied to the various styles of lathe and screw-cutting machinery with but slight additional expense, and that greatly enhances their output and decreases the cost of bolts, screws, and rods produced thereby.

The operation of our invention will be readily perceived from the foregoing description and upon reference to the drawings, and it is evident that the detail parts may be somewhat varied from that shown and described without departing from the spirit of the invention.

Having thus fully described our invention, what we claim as new, and desire to secure by Letters Patent, is—

1. The herein-described lathe attachment, the same comprising a cutting-tool support movable toward and away from the article to be cut, and a movable adjuster for automatically moving said support toward and away from the article to be cut, substantially as described.

2. The herein-described lathe attachment, the same comprising a movable tool-support, a contact-plate in the path of the article to be cut, and an adjuster D, substantially as described, between said contact-plate and tool-support, whereby the position of the latter is changed by movement of the former, substantially as specified.

3. The herein-described lathe attachment, the same comprising a frame along which the article to be cut is movable, a tool-support movable on the frame toward the article to be cut, a contact-plate in the path of the article to be cut, and an adjuster having one extremity secured to the contact-plate and the

other engaged by said tool-support for varying the position of the latter as the article to be cut moves the contact-plate, substantially as set forth.

4. The herein-described lathe attachment, the same comprising a frame along which the article to be cut is movable, a tool-support movable on the frame toward the article to be cut, a contact-plate in the path of the article to be cut, an adjuster having one extremity secured to the contact-plate and the other engaged by said tool-support for varying the position of the latter as the article to be cut moves the contact-plate, and a retractor for retracting the adjuster, substantially as and for the purpose set forth.

5. In a lathe attachment, the combination of a tool, an adjuster for bringing the tool toward and away from the article to be cut, and a contact-plate secured to said adjuster, whereby when the same is moved the position of the tool is varied, substantially as and for the purpose set forth.

6. In a lathe attachment, the combination of a tool, an adjuster for bringing the tool toward and away from the article to be cut, a bearing secured to said adjuster, and a contact-plate adjustably mounted in said bearing, whereby when the same is moved the position of the tool is varied, substantially as and for the purpose specified.

7. In a lathe attachment, the combination of a tool-support, an adjuster for automatically regulating the tool-support in relation to the article to be cut, a contact-plate adjustably secured upon said adjuster, and a retractor for returning the adjuster to its normal position, substantially as and for the purpose specified.

8. In a lathe attachment, the combination of a tool-support having an engaging-rib B' , an adjuster D , having a guideway d for receiving said rib B' , and a contact-plate G , carried by said adjuster, substantially as and for the purpose set forth.

9. In a lathe attachment, the combination of a tool-support having an engaging-rib B' , an adjuster D , having a tapered guideway for receiving said rib B' , a contact-plate G , adjustably mounted on said adjuster, and a retractor for returning the adjuster to its normal position, substantially as and for the purpose specified.

10. In a lathe attachment, the combination of a tool-support and an oppositely-arranged support for the article to be cut, an adjuster for engaging said supports and drawing them toward and away from each other, a contact-plate having one extremity secured to said adjuster and the other in the path of the article to be cut for bringing the adjuster into action, and a retractor for retracting the adjuster, substantially as and for the purpose described.

11. In a lathe attachment, the combination of a tool-support and an oppositely-arranged support for the article to be cut, an adjuster

for engaging said supports and drawing them toward and away from each other, a contact-plate having one extremity secured to said adjuster and the other in the path of the article to be cut for bringing the adjuster into action, a spring interposed between said supports, and a retractor for retracting the adjuster, substantially as set forth.

12. In a lathe attachment, the combination of a tool-support and an oppositely-arranged support for the article to be cut, ribs on the supports, and a movable plate having wedge-shaped guides for engaging said ribs, substantially as described.

13. In a lathe attachment, the combination of a tool-support and an oppositely-arranged support for the article to be cut, ribs on the supports, a movable plate having wedge-shaped guides for engaging said ribs, and a contact-plate secured at one extremity to said plate, substantially as specified.

14. In a lathe attachment, the combination of a tool-support and an oppositely-arranged support for the article to be cut, ribs on the supports, a movable plate having wedge-shaped guides for engaging said ribs, and a contact-plate adjustably secured at one extremity to said plate, substantially as set forth.

15. In a lathe attachment, the combination of a tool-support and an oppositely-arranged support for the article to be cut, ribs on the supports, a movable plate having wedge-shaped guides for engaging said ribs, a contact-plate secured at one extremity to said plate, and a retractor for returning the plate to its normal position, substantially as and for the purpose described.

16. In a lathe attachment, the combination of a tool-support and an oppositely-arranged support for the article to be cut, ribs on the supports, a movable plate having wedge-shaped guides for engaging said ribs, a contact-plate secured at one extremity to said plate, a retractor for returning the plate to its normal position, and a spring between the said supports, substantially as specified.

17. In a lathe attachment, the combination of the frame having guides, a tool-support, and a support for the article to be cut movable in said guides, a plate movable at right angles with the supports, wedge-shaped guides on the plate for engaging said supports, a contact-plate secured to said movable plate, teeth formed in the movable plate, and a gear for engaging said teeth, substantially as described.

18. In a lathe attachment, the combination of the frame having guides, a tool-support, and a support for the article to be cut movable in said guides, a plate movable at right angles with the supports, wedge-shaped guides on the plate for engaging said supports, a contact-plate secured to said movable plate, teeth formed in the movable plate, a revoluble spindle mounted on the frame, a recess in one of the supports to receive said spindle, and a

gear on the spindle for engaging the teeth on the movable support, substantially as specified.

19. The combination, with a frame, of a hinged bracket, a cutting-tool on the bracket, and a movable catch on the bracket for retaining it in operative position, substantially as set forth.

20. The combination, with a frame, of a hinged bracket, a cutting-tool on the bracket, a movable catch on the bracket for retaining it in operative position, a spring for forcing said catch into position, and a lever for rocking the catch against the action of the spring, substantially as specified.

21. The combination, with a tool-support and an oppositely-arranged support for the article to be cut, of an adjuster for varying the position of the tool-support, a contact-plate in the path of the article to be cut for bringing the adjuster into operation, a hinged bracket, and a second tool secured to said bracket, substantially as set forth.

22. The combination, with a frame, a tool-support, and an oppositely-arranged support for the article to be cut mounted on said frame, an adjuster for varying the position of said supports, a contact-plate for bringing the adjuster into operation, a hinged bracket, a second tool on the bracket, and a catch on the bracket for retaining it in operative position, substantially as specified.

23. In combination with a frame, a pair of

oppositely-arranged supports movable toward and away from each other on the frame, an adjustable bearing-face on one of the supports, an adjustable tool on the other of said supports, an adjuster for engaging the supports and bringing said bearing-face and knife toward and away from each other, and a contact-plate secured to said adjuster for bringing it into operation, substantially as set forth.

24. In combination with a frame, a pair of oppositely-arranged supports movable toward and away from each other on the frame, an adjustable bearing-face on one of the supports, an adjustable tool on the other of said supports, an adjuster for engaging the supports and bringing said bearing-face and knife toward and away from each other, a contact-plate secured to said adjuster for bringing it into operation, and a retractor for returning the adjuster to its normal position, substantially as specified.

In testimony whereof we have hereunto signed our names, in the presence of two attesting witnesses, at Syracuse, in the county of Onondaga, in the State of New York, this 7th day of October, 1890.

JOHN LINDSTROM.
EDWARD F. BERGMAN.

Witnesses:

CLARK H. NORTON,
H. E. CHASE.